



INDIA'S LARGEST **GREENHOUSE** MANUFACTURER



www.protectedcultivation.com

We are the **architects** who build houses for the plants to grow at their **best**



Founded in 2013, Agriplast Protected Cultivation Private Limited emerged from our founders' 50+ years of experience in hi-tech agriculture and collaborations with leading global companies. Dedicated to transforming India's greenhouse industry, we address the challenges posed by a growing population, diminishing land, and chemical reliance in agriculture with innovative, smart farming solutions. We offer top-grade polyhouses, greenhouses, and other sustainable structures, designed using Israeli technology and built with the highest quality materials. Additionally, we provide comprehensive Greenhouse Turnkey Project Services and Agricultural Advisory Services. Our expert team delivers tailored solutions, ensuring exceptional outcomes and driving continuous growth, affirming our commitment to enhancing farmer profitability through sustainable practices.

Our **Vision**

Transforming agriculture with technology-driven solutions at every stage of farming.

Our **Mission**

To pioneer sustainable protected cultivation technology solutions, ensuring food security, prosperity for farmers, and a Clean food revolution for the future.



Rely on **Agriplast**



We understand farmers' needs and relationship between plants and structures



Professional and dedicated team with hands-on experience in the field of protected farming



Customized Design Solutions to meet your requirements



Precise manufacturing technology with latest machineries to ensure uniform quality production



Agronomy support from professionally trained agronomists



In-house research team to provide you with the latest solutions respective to the crop and climate as per your needs



Board of **Directors**



Mr. Rajeeb Kumar Roy
Chairman

Protected Farming Expert

Rajeeb Kumar Roy is a technopreneur and pioneer in the field of protected farming solutions. He holds a Master's Degree in Agricultural Engineering from IIT Kharagpur and a Diploma in Executive General Management from IIM Bangalore. Over the last 23 years, he has been associated with many Israeli and Dutch companies, introducing numerous innovative concepts in this field. His experience and scientific approach have benefitted many farmers, both qualitatively in terms of produce quality and quantitatively in terms of output volume.



Mr. Neeraj Roy
Director

Farming Tech Expert

Mr. Neeraj Kumar Roy has always been a visionary entrepreneur who passionately embarked on his business journey in 1995. He gained hands-on experience in five different businesses before accumulating over 15 years of in-field experience in the protected cultivation industry. With a strong grasp of Import/Export, Banking, Logistics, and Sales & Purchases, he serves as the backbone of the company, leveraging his extraordinary knowledge and experience. Mr. Roy possesses outstanding systematic and methodical problem-solving abilities, as well as exceptional negotiation skills. He oversees the entire management process, and his impact on the organization is highly recognized and respected.



Mr. Abhishek Bhatt
Managing Director

Greenhouse Tech Expert

Abhishek Bhatt holds a B.Tech (ME) degree and has been an entrepreneur since the beginning of his career in 2011. With experience in developing untapped markets from scratch, he commenced his journey by engaging in farming on leased land for three years to gain firsthand knowledge of the challenges and hardships faced by farmers. Understanding the struggles, he tailored solutions to suit local conditions. Abhishek was a pioneer in developing technology platforms that connected farmers and suppliers across Pan India. His vision is to provide cost-effective and innovative solutions to reach even the smallest farmers and make a significant impact on their lives. He is responsible for driving innovation and spearheading the growth of the organization.

Growing **Team**



Mr. Ashish Anand
Chief Executive Officer

Protected Farming Expert

Ashish Anand, the dedicated CEO of Agriplast Protected Cultivation, is a stalwart in the realm of protected farming and a trusted consultant for polyhouse solutions. With extensive experience and a deep-rooted commitment to sustainable agricultural innovations, he stands as a beacon for farmers. His vision is to revolutionize the agricultural landscape, empowering farmers through cutting-edge technologies and expert guidance. As a seasoned professional, he brings a wealth of knowledge in crop production and sustainable techniques. His efforts have positively impacted countless farmers, making him a crucial force in the journey towards more efficient and sustainable farming practices.



Mr. Peeyush Pandey
Senior Agronomist

He completed his Masters in Horticulture (Vegetable Science) at U.P. College, Varanasi, in 2005. Over the years, he has gained valuable experience working with companies like Reliance, Netafim, and D S Group, encompassing a variety of domains related to crop production and advanced sustainable techniques. He possesses expertise in guiding small-scale vegetable growers as well as large commercial farms, introducing them to modern farming facilities such as Greenhouses, Automation, Hydroponics, and more. Throughout his two decades of experience, he has played a pivotal role in cultivating over 1000 acres of open-field farming and protected cultivation. Notably, during his tenure at DS Group, he initiated advanced farming with a hydroponic system for blueberries. Many success stories of farmers in North India owe their guidance and development, end-to-end, to his expertise.

Team of Experts
with the combined experience of

50+ Years

Team Strength
with total members

100+

Experience of Building
Polyhouses in more than

1000+ Acres



World-Class Infrastructure

Israeli Technology designed for **India**

We pride ourselves on our world-class infrastructure, establishing us as a leading polyhouse manufacturer in India. Our extensive facilities boast some of the largest polyhouse factories in the country, symbolizing our commitment to excellence. With cutting-edge technology and dedicated expertise, we ensure that our infrastructure aligns with our mission to provide top-tier solutions for protected cultivation. This infrastructure empowers us to deliver unmatched quality and innovation, meeting the diverse needs of farmers and contributing to a sustainable future for agriculture in India and beyond.





3 Continents

18+ Countries

1000+ Projects

100+ Cities

5000+ Happy Families

100+ Dynamic Team Members



ADVANTAGES OF AGRIPLAST POLYHOUSE

- ✓ 100% Pre-fabricated structure, ready to assemble and easy to re locate.
- ✓ GI pipes exceeding 350 GSM, offered in spans of 8m and 9.6m, supporting higher structures up to 7-8m with gutter height from 4-5m and side ventilation of 4-5m, complemented by top ventilation at 1.2-1.3m.
- ✓ Capable of reaching 80% ventilation in naturally ventilated polyhouse.
- ✓ Use of 1.6 mm to 2 mm thick gutter with a minimum zinc coating of 275 GSM.
- ✓ Use of gutter at last bays for better rain water harvesting and reinforcement.
- ✓ Sliding Aluminum double door with UV Stabilized polycarbonate sheet.
- ✓ Well designed aluminium profiles and imported coated springs for locking of plastic.
- ✓ Connectors thickness from 2mm to 5mm (with electro galvanizing upto 20 microns).
- ✓ Option of Intermediate hockey every 2 m along the gutter length.
- ✓ Option of choosing two sided (Only along the gutter length) or 4 sided hockey.

Secondary Layer Mechanism

- A. Fixed Secondary Layer
- B. Movable Secondary Layer
 - Rope System,
 - Manual screen movement with chain pulley
 - Motorized screen movement with GI wire rope mechanism
 - Motorized rack and pinion system
 - Motorized with automation with temperature control sensors

Curtain System

- A. Anti-flap side curtain box and to cover the partition
- B. Different types of mechanisms:
 - Normal pipe rollup curtain assembly
 - Chain rollup curtain mechanism
 - Motorized curtain mechanism
 - Motorized cum automated mechanism with temperature sensors

Option to install screen movement system above the greenhouse structure.

- A. Fixed shadenet on top of polyhouse above the gutter
- B. Motorized shadenet mechanism on top of polyhouse above the gutter

Anti Hail reinforcement above the polyhouse structure.

Imported Insect nets on the side, 40 to 50 Mesh, 110 to 120 gsm (+ or - 5 gsm) with a **warranty of 5 Years.**





POLYHOUSE SOLUTIONS

POLYHOUSE SOLUTIONS

MAXIMUM VENTILATION

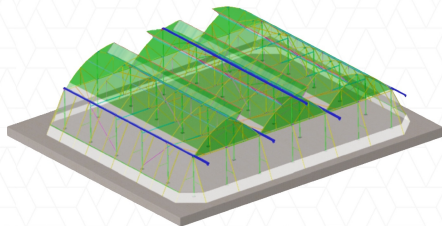
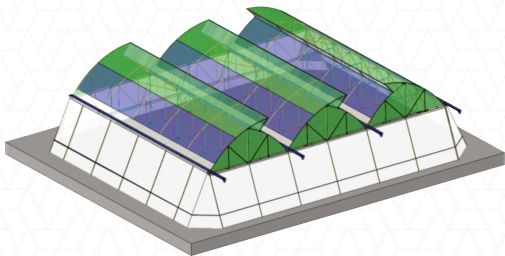

NATURALLY VENTILATED POLYHOUSE

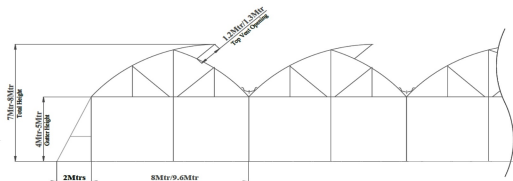

BUTTERFLY VENT POLYHOUSE

All Column Size : 76mm OD x 2mm / 80-40 X 2mm RHS

Intermediate Column : 60mm OD x 2mm / 80-40 X 2mm RHS

Hockey : RHS 60 x 30 x 2mm

Gutter : 1.6mm - 2mm

Trellising load 25kg per m²

CUSTOMIZED POLYHOUSE

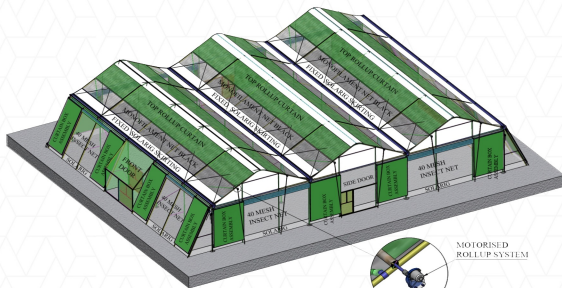

MOTORISED
ROLLUP SYSTEM

Interchangeable nethouse and polyhouse based on the cropping requirements. Recommended for farmers who are interested in growing both vegetables and flowers in the same field at different times of the year.

All Column Size : 60mm OD x 2mm Pipe
Intermediate Column : 48mm OD x 2mm Pipe
Hockey : 60 x 30 x 2mm RHS
Gutter : 1.6mm - 2mm
Double Layer & Trellising Optional
Trellising load 25kg per m²

Polyhouse with top retractable roof. Recommended for high temperature and humid agro-climatic conditions.



TURNKEY SOLUTIONS



CABLE PURLIN FLAT ROOF NETHOUSE

VEGETABLE NETHOUSE

Grid Size : 8m x 5m / 9.6m x 5m

Height of Structure : 4m to 5m



POMEGRANATE NETHOUSE FOR HAIL PROTECTION

Height of Structure : 5m (Flat Roof)



BANANA NETHOUSE FOR WIND PROTECTION & WATER SAVING

Height of Structure : 6m

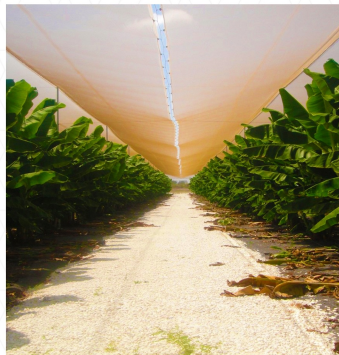

*Agriplast Nethouse incorporates covering materials

NET HOUSE SOLUTIONS

A net house is a structure made of hot-dip galvanized steel pipe sections with special reinforcement that allows sunlight, moisture, and air to reach the crops. It creates an ideal climate for plants to grow healthily. Net houses are mostly used in hot and humid climates where growing in a polyhouse becomes difficult.

• Flat Roof Cable Net House • Tubular Section Dome Net House • Flat Roof Tubular Net House



FLAT ROOF CABLE NET HOUSE

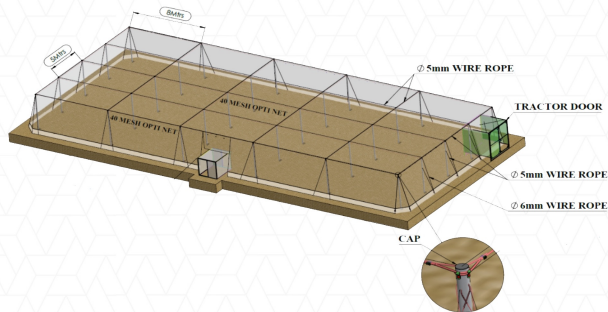

FOUNDATION

Peripheral pillars metal mold with concrete casting.

Internal pillars two metal angles ready to be buried into the soil.

ANCHORS

Peripheral anchors are made of 14 mm metal rod ready to be cast in concrete.

WIRE ROPES WITH SPECIAL HOLDING CONNECTORS

At the roof level we use strong wire rope of 5 mm diameter. For the anchors on the periphery we use wire rope 6 mm diameter. 4mm special wire is used for Trellising.

SPECIFICATIONS

Galvanized Iron Pipe-Peripheral columns 90x2.5mm/4mm thick - 400 +GSM Zinc coated

Galvanized Iron Pipe -Internal columns 60x2mm / 3 mm thick - 400+ GSM Zinc coated

OTHER RELEVANT INFORMATION

- 100% Pre Fabricated structure, ready to assemble and ready to relocate ,guaranteed for 100 kmph wind speed.
- Structure with connectors are specially designed to break open beyond wind speed of more than 65kmph to prevent complete collapse of the structure and crop damage.
- Available at height of 4 mtr , 5 mtr, 6 mtr.
- Double Sliding Aluminium door with UV stabilized polycarbonate covering.
- Specially designed nut bolts.
- Connectors thickness ranging from 2mm to 5mm (with appropriate galvanizing to last longer).
- Specially designed dutch and spanis type trellising system to support the crop load of 25 kg/sqm.
- Scope of addressing the customized requirement of the farmer as per their crop, local agro-climatic and geographical location.

FLAT ROOF CABLE NET HOUSE



TUBULAR SECTION DOME NET HOUSE

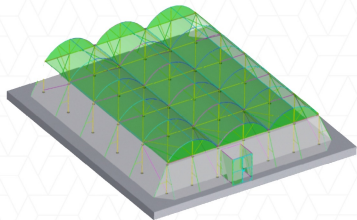

OTHER RELEVANT INFORMATION

100% prefabricated structure, ready to assemble and relocate.

All tubular sections hot-dipped to a minimum of 350 GSM. Sliding aluminum door with UV-stabilized polycarbonate covering.

Connectors with a thickness ranging from 2mm to 5mm (with appropriate galvanizing for longer durability).

Specially designed Dutch and Spanish trellising systems to support a crop load of 25 kg/sqm.

Scope to address the customized requirements of farmers based on their crops, local agro-climatic conditions, and geographical location.

FLAT ROOF TUBULAR NET HOUSE

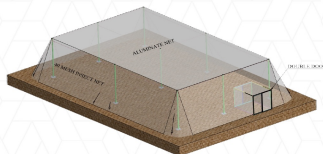
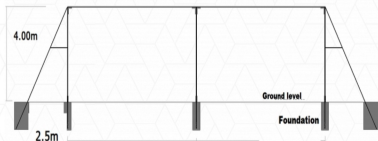



TUNNEL SOLUTIONS



TYPES OF TUNNELS

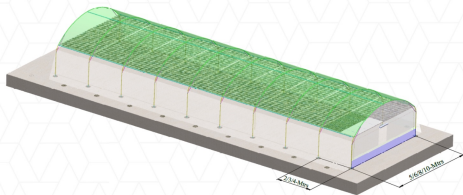

High Tunnel of grid size (mtrs) : 5/4,5/3, 6/4,
6/3,6/2, 8/4, 8/3,8/2, 10/4, 10/3,10/2

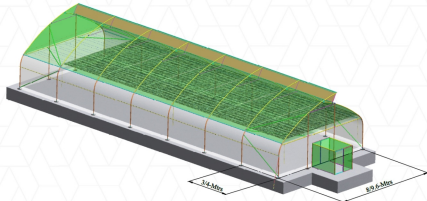

Top Tunnel of grid size (mtrs) : 8/4,8/3, 9.6/4, 9.6/3

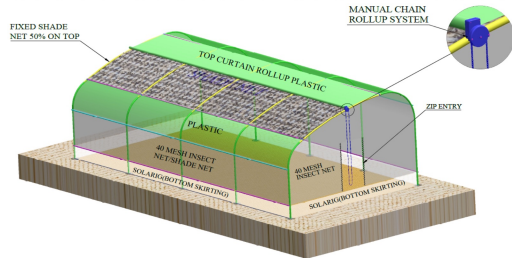

CONVERTIBLE TUNNEL

Convertible tunnel which works as a net house and polyhouse based on the requirements suitable in areas where cold and heat both are extreme.



BOOM IRRIGATION

This product is brought to you through technical tie-ups with an international industry giant from Italy, a world pioneer in the field of boom irrigation.

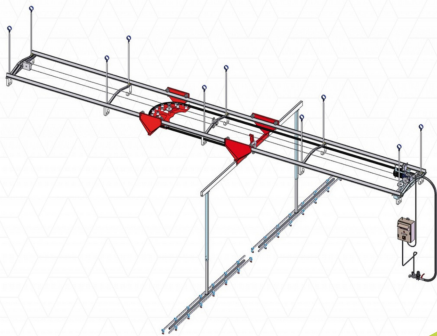

TECHNICAL SPECIFICATIONS



- Double rail with inter-axis 1000 mm.
- Trolley with wheels mounted on bearings.
- Nozzle bar with single or double row mounted on stainless tube.
- Water connection of 1" or 1 ¼".
- Working speed adjustable from 2 m/min.
- 16 m/min., other speeds at request.
- Boom movement with iron cable.
- Working length up to 200 m.
- Installed power 230V 0,5Kw 50/60Hz

SIDE CURTAIN MECHANISM

(A) Anti flap side curtain box and to cover the partition

The Anti-Flap Side Roll-Up Curtain Box is engineered to minimize wind-induced damage and safeguard the structure against rainwater infiltration at the side curtain partition.

(B) Different types of side curtain roll up mechanism

NORMAL PIPE ROLLUP CURTAIN ASSEMBLY

- 27mm / 34 mm OD pipe x 2mm hot dip galvanized pipe section for rollup handle assembly.
- Most economical.

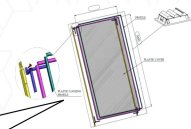

SIDE CURTAIN MECHANISM

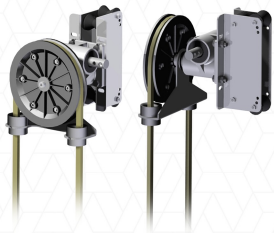

- A** Entry-level includes manual gear chain, pulley, and sliding guide plate for diagonal side ventilation. In this case, your curtain is on the rolling pipe that moves up-down and the gear follows the pipe thanks to the sliding guide for pipe (in diagonal parallel the side) in diameter 270D or 330D. The maximum length with this application is 65/75 meters long.
- B** The second level includes manual gear with telescopic arms. In this case, you have the gear fix on the structure and the telescopic arm moves the side curtain with the rolling pipe, the worker moves the gear. Thanks to the drill machine with a battery that moves the hexagonal key of the gear, the telescopic arm moves the curtain up and down. The maximum length with this application is 70/80 meters long.
- C** The top-level includes a telescopic arm and gear motor. This is the perfect option to implement. One gear motor, box control, and cable are required in this application. The maximum length with this application is 90 meters long.

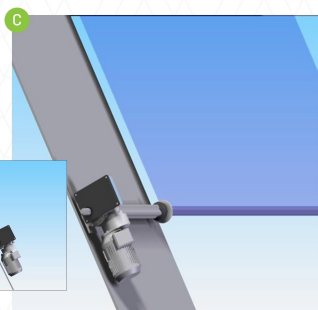

SECONDARY LAYER SHADE NET MECHANISMS

Double layer net in a spread condition can block and reflect thus reduce the incident IR radiation to the plant. It reduces the temperature in the hot and sunny day. During the winter the same net is spread in the night. It retains the reflected IR radiation under the screen, keeps the night temperature higher and maintains healthier growing conditions for the plants.

(A) Rope System

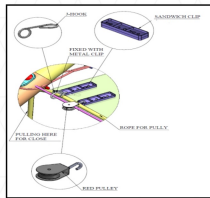

This is the traditional secondary layer mechanism, where a secondary layer shade net can be operated with the assistance of UV-stabilized rope. Special connectors and pulleys are designed and utilized to facilitate smooth operation. For instance, connectors like the sandwich clip have been specifically designed to prevent tearing of the secondary layer caused by rubbing against the steel wire rope.

(B) Manual screen movement with chain pulley

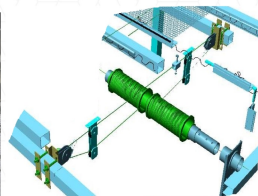

A chain pulley as shown in the picture is used to make the manual movement of secondary layer screen.



SECOND LAYER SHADENET MECHANISM

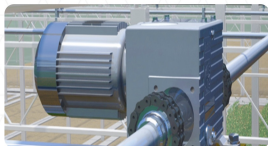
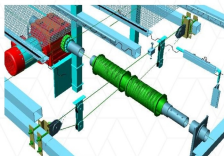

(C) Motorized Screen Movement

The system employs an electrically powered motor for screen movement.

A double out shaft motor facilitates rolling up the screen on both sides.

High power and torque capacity, allowing for up to 60 meters of shaft length and approximately 4000-6000 sqm coverage.

Equipped with a dual limit switch protection for added safety.

Precise limit switch and secure self-locking feature ensure reliability.

Water drain feature added to protect the safety of the circuit diagram.

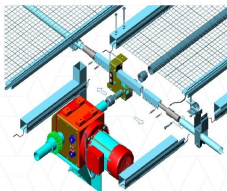

(D) Motorized Rack And Pinion system

Agriplast has pioneered a horizontal trussed shade structure, introducing a highly advanced retractable shade system.

Key features includes:

The cutting-edge screen automation system for seamless closure.

Longevity and negligible maintenance requirements.

Robust steel racks and precision Dutch-made pinion assemblies.

SHADE NET MECHANISM OVER THE GREENHOUSE / POLYHOUSE

- Fixed Shade net on top of polyhouse structure
- Motorized retractable screen mechanism on top of the poly house structure

Energy/shade screen systems can provide 30 to 50% savings in heating and cooling costs. Often referred to as energy blankets, they save energy by reducing the heat loss surface area, providing an extra insulation barrier and trapping a layer of dead air on both sides of the screen material. (On winter nights) If the above screen is aluminum, the infrared part of the heat will be reflected back and will reduce fan operation cost (in the summer).

An energy/shade screen is a mechanical system consisting of a drive motor, support cables, energy/shade material and controls. A single gear motor is needed to power the drive system (OR) fixed on top of the poly house.

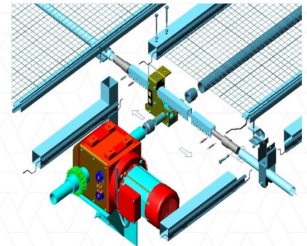
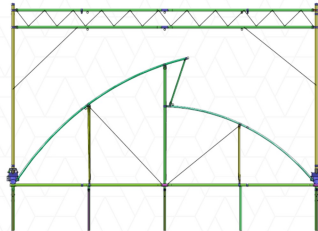

TOP DOUBLE VENT OPENING

Increases in temperature and humidity damages the yield and affect the quality of the crops.

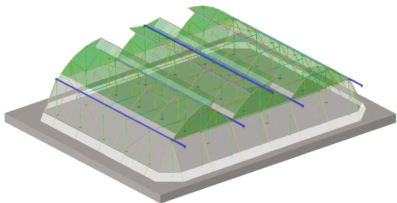

(A) FIXED DOUBLE TOP VENT OPENING

- Lower installation and maintenance costs.
- No need for electricity.
- Allows for longer gutter front lengths along the greenhouse.

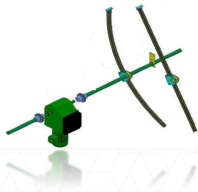

Top Vent Rack & Pinion Mechanism

(B) MOVABLE DOUBLE TOP VENT OPENING

This solution necessitates the installation of a ventilation system within the greenhouse. It empowers growers to attain optimal internal climate conditions, yielding better annual results without relying on external conditions.



VENT OPENING ALONG WITH GABLE LENGTH

This model is used to provide maximum ventilation along the gable side.

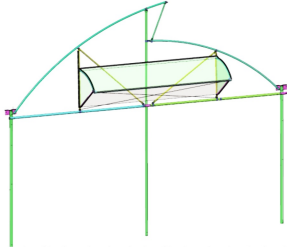

(A) FIXED VENT OPENING ALONG THE GABLE LENGTH

- Lower installation and maintenance costs.
- No need for electricity.
- Allows for longer gutter front lengths along the greenhouse.



Rack & Pinion

(B) MOVEABLE VENT OPENING ALONG THE GABLE LENGTH

This solution requires the installation of a ventilation system within the greenhouse. . This helps to Control over climate conditions. Farmers can expect better annual results without dependency on external conditions.



FORCED VENTILATED STRUCTURE / FAN & PAD SYSTEMS

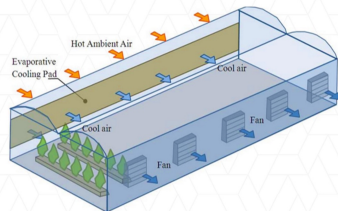
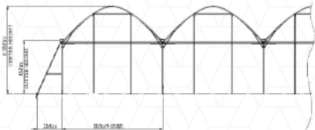
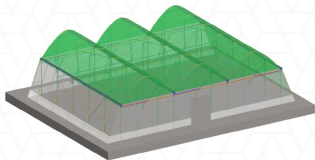

The greenhouse climate control system is engineered to world-class standards and widely preferred by greenhouse growers to manage energy costs, maximize crop yields, and aid in fertilizer and water conservation. These systems incorporate greenhouse automation technology and utilize the latest green technology, designed to be environmentally friendly and cost-effective. They efficiently regulate humidity, CO₂ levels, temperature, and lighting, as well as control fog, misting, thermal conditions, and solar shading. These devices represent the most advanced and user-friendly Greenhouse Climate Control System.

SPECIFICATIONS

- Fan with auto-opening shutters, damper type, 415 V, 50 Hz, 1.5 h.p Motor.
- Cellulose cooling pad, 4" - 6" thick & 4" - 6" height.
- Frame for the above cooling pads with top water distribution and bottom gutter.
- Automatic temperature and humidity controller, micro-processor temperature and humidity sensors.



The image shows the interior of a large greenhouse. The structure is supported by a metal frame with a translucent covering. Rows of young green plants are growing in black plastic trays. A complex network of pipes and electrical conduits is visible on the ceiling, with several white, dome-shaped fans hanging from the structure. The lighting is bright and even, highlighting the organized layout of the growing area.

FAN & PAD SYSTEM

FORCE VENTILATED STRUCTURE

Fan & Pad greenhouses utilize the principle of evaporative cooling. Evaporative cooling involves the transformation of water into vapor when heated. During evaporation, heat is absorbed from the water, causing it to remain in a cooler liquid state. When air is circulated through this cooler liquid within a confined space, it effectively cools the entire area it passes through, creating the desired climatic conditions.

FAN & PAD SYSTEM

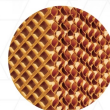
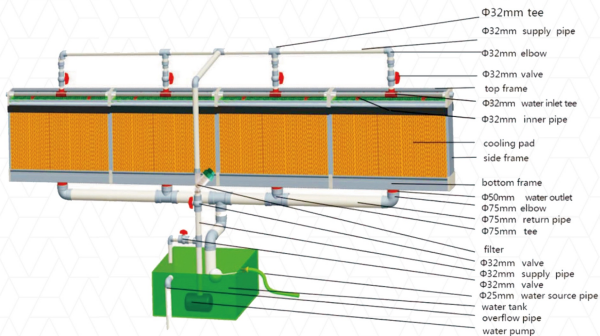

Brown



Yellow

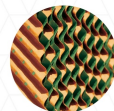

Green-Brown



Single Black



Green

GREENHOUSE AUTOMATION

PRIVA

Our Greenhouse Automation Systems are versatile and ideal for various greenhouse scales, from small farmers to large commercial operations. Through greenhouse automation, growers can enhance crop yield, improve crop quality, and reduce operational costs. This system achieves an optimal climate for crops by monitoring and controlling temperature, humidity, light, and CO2 within the greenhouse. Agriplast Automation Systems are user-friendly, allowing convenient access via smartphones, tablets, or computers from any location.

PRIVA AUTOMATION

AUTHORISED
CHANNEL PARTNER



It is an affordable integrated control system for greenhouse control operations.



The PRIVA Compass is a user-friendly Control system that can control irrigation, climate, photosynthesis, fertigation and energy for one or twenty compartments.



Multiple compass can be connected together for controlling more greenhouses as required.



Easy to operate with clear controls with dashboards and graphs.



Operated by Smartphone, Tablet or PCs



24 / 7 Online and offline help function



AGRIPLAST AUTOMATION



Suitable for all types of crops and greenhouses including the reuse of drainage water



The PRIVA Compact incorporates the perfect basic controls for climate and water dosage in combination with a simple operation.



PRIVA Compact enable growers to manage the essential growing conditions in the greenhouse 24/7, including ventilation, cooling, heating, curtains, CO2, fans, humidification, lighting, irrigation, fertilizer dosage and the reuse of drainage water.



Operated by Smartphone, Tablet or PCs with online and offline support



INDIA'S MOST EFFICIENT AUTOMATION SYSTEM



Automatically manage your nutrient and pH levels, set remote alarms and data log your progress with one simple controller.

The IntelliDose sets the industry standard for a small commercial auto-dosing. Dose up to a 9-part blend (nutrients, additives, pH adjuster) while maintaining your preset EC and pH settings.



IntelliDose



IntelliClimate

FEATURES

- Controls all growing methods - NFT, DFT/DWC, soil, media, drip, and aeroponics
- Measure nutrients in EC/CF/TDS (500/640/700 scale)
- Lower or raise pH
- Able to set different EC for day and night
- Able to lower EC by adding water
- Receive or SMS alerts
- Irrigation pump outputs
- Fail-safe dosing shutoffs

SPECIFICATIONS

- 9 outputs 24VDC (or same voltage as supplied by plug pack)
- Nutrient measurement units EC, CF or TDS (500/640/700)
- Measured range 0.00 to 9.99EC, 0.1 to 99.99CF, 0 to 7000PPM
- Nutrient resolution to .01 mS/cm, 0.1 CF
- Nutrient measurement accuracy +/-0.1 EC, 1.0CF or IOPPM (temperature compensated)
- Nutrient dosing range 0.00 to 5.99EC, 0.1 to 59.9CF, 0 to 4200PPM
- pH resolution and accuracy - 0.1 pH
- pH measurement range 2pH to 12pH
- Nutrient and pH dosing times settable from 0 minutes to 254 minutes
- Dosing interval settable from 0 minutes (continuous dosing) to 254 minutes
- Sequential dosing to prevent power surges
- Solution temperature accuracy 1 °C/2°F
- Temperature range 0-50°C/32-125°F
- Operating temperature range 0-50°C/32-125°F (not in direct sunlight)
- Power source - 120V/240V into 24VDC plug pack (supplied)



AGRIPLAST HYDROPONICS



IN HOUSE SUBJECT EXPERTS

Agriplast has Inhouse Designers , Structural, Electrical and software engineers and Agronomist with collective 50+ year of experience to ensure the best project execution and unmatched service support to our clients.



AUTOMATIC NURSERY SYSTEM

Agriplast uses ebb and flow technology for the nursery of the plants. Ebb and flow gives best results as each net pot get same uniform water and nutrient.



INNOVATIVE NFT CHANNELS

Compared with round pipe and square pipe, we only need much less water to the vegetables. What's more, water will only flow in Centre part with our channel, while it may go sides with flat bottom channel from other suppliers. And save water and fertilizer 80%.



BEST MATERIAL QUALITY

We use food grade material right from NFT channels. Nutrient supply & drainpipe to head unit's fittings.



Advantages of Agriplast Hydroponics



An extended growing season

In a hydroponics system, plants can be grown hydroponically year-round because the grower controls the temperature, light, and nutrient-supply. For leafy we can get Multiple crop cycles all around the year.



Improved growth and yield

Hydroponics systems typically result in faster-growing, higher-yielding plants. This is likely due to the increased oxygen levels found in the nutrient solution and the carefully controlled environmental factors.



Can grow anywhere

Unlike traditional gardens that require outdoor space for plants, hydroponics systems are easily incorporated into many homes, regardless of their size or location.



Higher Plant Density

Plants grown in soil have rigid spacing guidelines that must be followed to allow each plant equal access to the soil's somewhat limited supply of water and nutrients. Because hydroponics systems deliver a more nutrient-charged solution to the root zone.



GLIMPSES OF **AGRIPLAST** STRUCTURES





AGRIPLAST SUCCESS STORIES



An IT Expert turns Farmer

Meet Mohan Arasu, a former JP Morgan employee who left the IT world to revolutionize agriculture and co-founded Bhoomi Farms.

Bhoomi Farms is now running successfully and has expanded to include an Organic Products Online Store, offering delivery across Bengaluru and nearby areas.



Growing more than code

Meet Pranjal Mishra, a seasoned IT Engineer with 15 years of industry expertise, who chose to embark on an inspiring entrepreneurial journey in the realm of farming.

Venturing into the world of protected farming seemed daunting until I was introduced to Agriplast. Their level of professionalism and attention to detail was truly awe-inspiring.

Pranjal is now engaged in protected farming on one acre of land, generating approximately ₹15,00,000 in revenue every year.



AGRIPLAST SUCCESS STORIES



Agriplast team build my confidence for doing protected cultivation. Agriplast team supported all the way for not only establishing but also operating the project.

SANDEEP KANAN
TIRUPATI, ANDHRA PRADESH



I chose Agriplast to construct my Polyhouse because it's the only company that maintains professional international standards and complies with government norms in the construction of Polyhouses. More importantly, they provide guidance from experienced agronomists. I've been practicing protected farming with them since 2019.

BRIJMOHAN RANA
MEERUT, UTTAR PRADESH



Agriplast's dedicated team provided steadfast support throughout the project's establishment and ongoing operations, ensuring its success and smooth functioning. Their expertise and guidance were instrumental in making the endeavor a triumph.

GURPREET SINGH
LUCKNOW, UTTAR PRADESH



In choosing Agriplast for Protected Farming solutions, I witnessed phenomenal results. Their expertise and support have truly made a significant difference in my farming endeavors.

SIDHANT SISODIA
FIROZABAD, UTTAR PRADESH



I chose Agriplast to construct my Polyhouse as it is the only company which maintains Professional international standards.

ABHISHEK SINGH
FIROZABAD, UTTAR PRADESH





*Recognized by Walmart International

Agriplast salutes Women Agripreneur Mrs. Deepti Chauhan for her hard-work & for inspiring millions of women across the globe.



OUR CORPORATE CLIENTS

eekifoods
Good for nature. Good for you



Select
GROUP



Seeding goodness

KIBOKO

syngenta



سابک
sebic

OUR GLOBAL PARTNERS



Autogrow

GINEGAR
smart cover solutions

POLYSACK
flexible packaging

mapal

CAREL

NETAFIM

URBINATI

VIALE SISTEMI
Drive Systems



agriplast
protected cultivation
smart farming solutions

YOUR PROTECTED FARMING PARTNER

CUSTOMER SUPPORT **+91 7676600777**



Agriplast Protected Cultivation Private Limited
Survey No 97 & 98, Chennachandram Village,
Marachandram, District-Krishnagiri,
Hosur Taluk, Pin - 635109



+91-87540 17190 / +91-88704 70266



info@protectedcultivation.com



www.protectedcultivation.com